



**Parapan<sup>®</sup>**

high gloss acrylic



solid high gloss doors...





with style...





with shine...







with quality...



Kitchen by Matthew James Kitchens



with colour...





with curves...



Kitchen by Alwood





with wood...







in your kitchen...





in your bedroom...





**Parapan**<sup>®</sup>  
high gloss acrylic

in your bathroom...



## Special Parapan<sup>®</sup> Applications



finger pulls



island units



wine racks



curves



office



furniture



handleless

## Parapan® Doors...

- ... are the finest quality solid high gloss kitchen doors and drawers on the market.
- ... are SOLID, they are 18mm thick acrylic all the way through, not coated or laminated. This is also why they are so unique!
- ... are hard-wearing, durable, moisture resistant and hygienic, ideal for the kitchen and bathroom environment.
- ... are available in 24 beautiful colours.
- ... are UV stable so will not fade.
- ... are bespoke, they are made to any size to suit your design requirements.
- ... can be thermoformed into curves.
- ... are available with a choice of interesting and unusual edge treatments.
- ... can easily be drilled for hinges and handles.
- ... are easy to maintain with non-abrasive household cleaners. Any eventual scratches can be removed simply by buffing with T-Cut® or Brasso®. Also available is the Parapan care & maintenance kit.
- ... can be cleaned with Parastat, an anti-static cleaner that is available from us.
- ... are also available in 4mm thickness in all the colours for splashbacks, light pelmets, cornices or front panels for built-in appliances.

Features	Benefits
Solid	Non Porous Waterproof Stain resistant Easy to clean Hygienic - Germ Free Repairable Will not delaminate
Acrylic	UV-Stable Colour stable Will not fade Thermoformable
High quality	Exclusive Upmarket
Brilliant/Vibrant colours	Creative
High Gloss	Reflective



## 4mm Panels & Splashback Range

**Alpine White**  
5910



**White White**  
5907

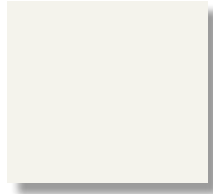

**Light Grey**  
5290

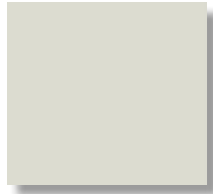

**Cream White**  
5196

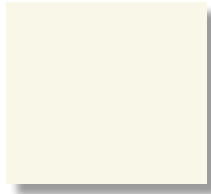

**Ivory (Beige)**  
5525

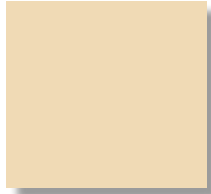

**Latte**  
5772

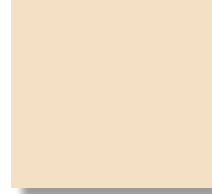

**Cappuccino**  
5773

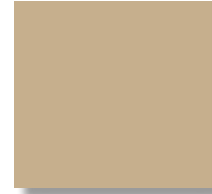

**Stone Grey**  
5295



**Red**  
5655



**Maroon**  
5771



**Lime**  
5440



**Dark Cyan**  
5471

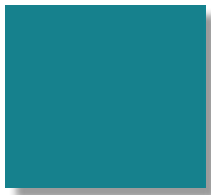

**Royal Blue**  
5380



**Black**  
5299



**Zest Yellow**  
5001





## 18mm Door Range

**Alpine White**  
5910



**White White**  
5907

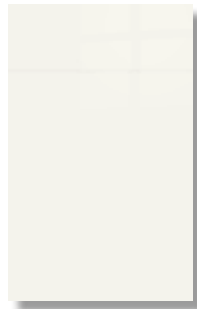

**Light Grey**  
5290

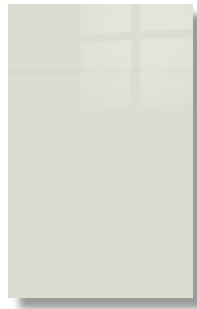

**Grey**  
5068

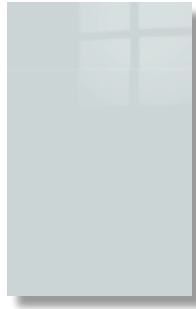

**Cream White**  
5196

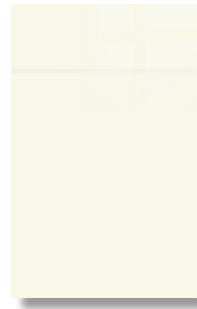

**Ivory (Beige)**  
5525



**Latte**  
5772



**Cappuccino**  
5773



**Stone Grey**  
5295



**Red**  
5655



**Maroon**  
5771

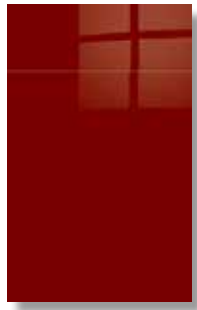

**Lime**  
5440



**Anthracite**  
5297

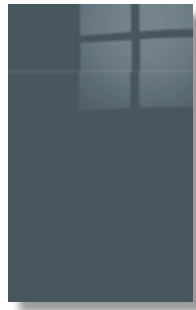

**Black**  
5299



### Matt finishes

**NEW**

**Alpine White**  
5910DC

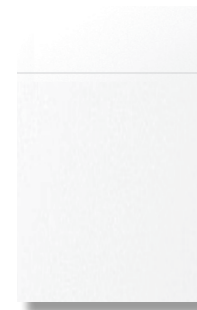

**Black**  
5299DC



## Parapan<sup>®</sup> Edge Treatments and Finger Pulls

Below is a choice of interesting and unusual edge treatments available for 18mm thick Parapan<sup>®</sup> doors. This provides an original and unique touch to the finished product.

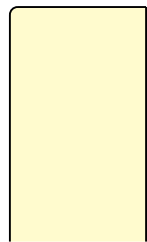

**1mm  
Radius Edge**  
FF01/A

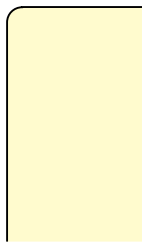

**2mm  
Radius Edge**  
FF01/B



**3mm  
Radius Edge**  
FF01/C

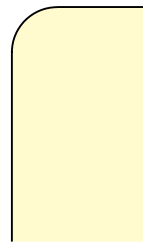

**6mm  
Radius Edge**  
FF01/D

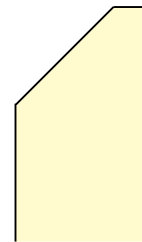

**Straight Rear  
Finger Pull**  
FF04

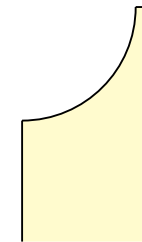

**Curved Rear  
Finger Pull**  
15mm Radius  
FF02

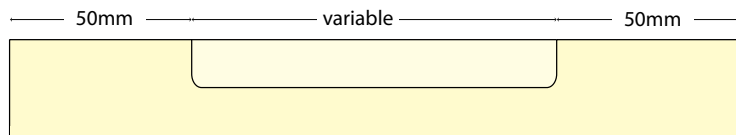

**Scooped Rear Finger Pull**  
FF08

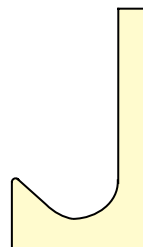

**Front Swept  
Finger Pull**  
FF07

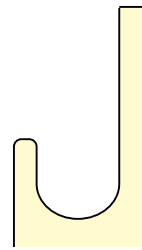

**Front Curved  
Finger Pull**  
FF09

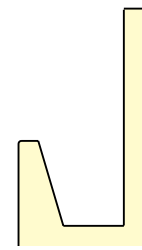

**Front Straight  
Finger Pull**  
FF10

(not available on curved doors)

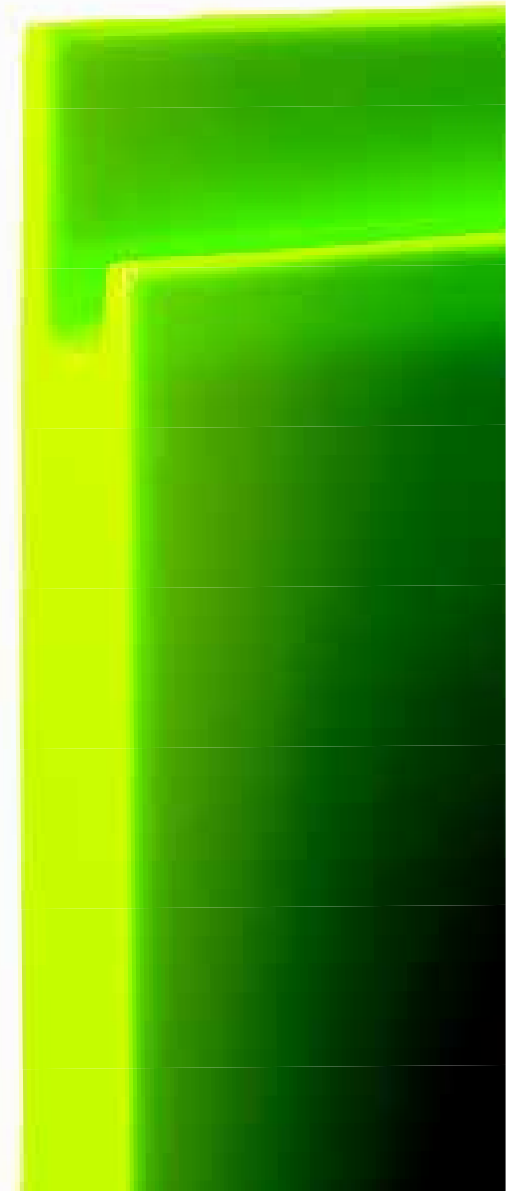

## Parapan® Finger Pull Handles

Below is a choice of finger pull handles.

Please note: Front finger pulls are not available on curved Parapan® doors.

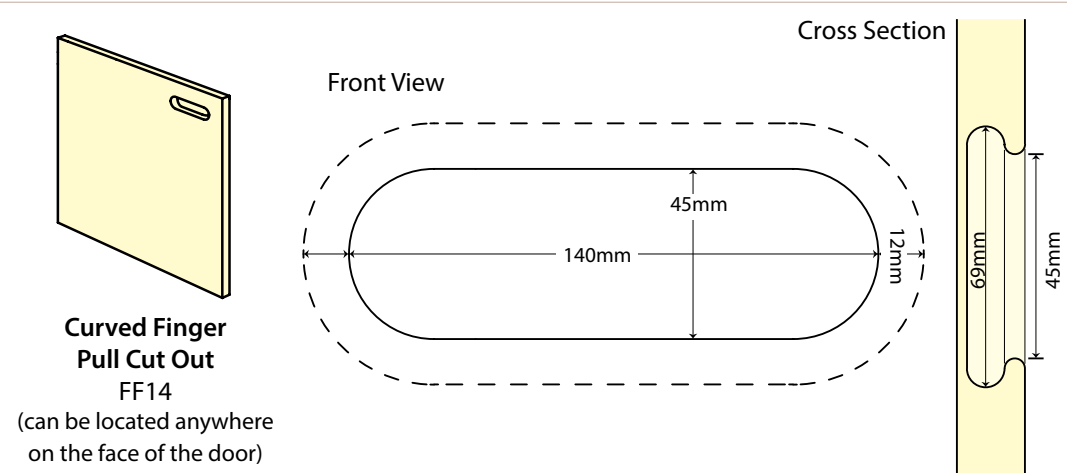
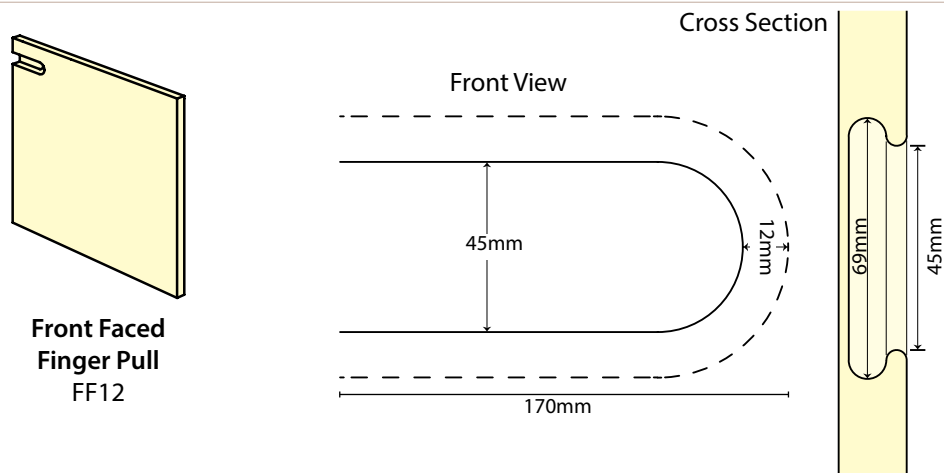
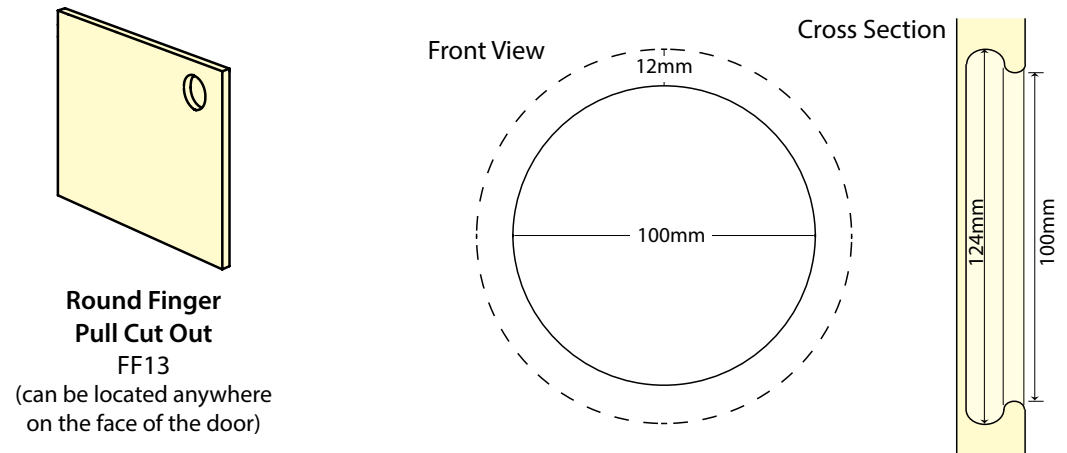
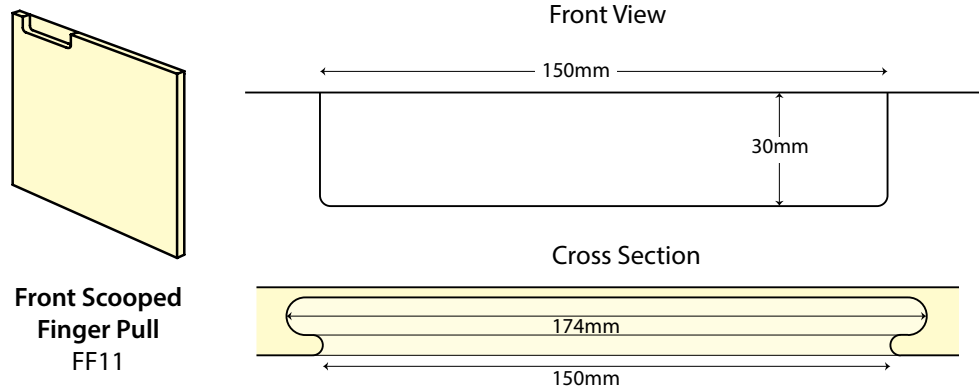

## Technical Data

Parapan® furniture-fronts made from solid 18mm acrylic and 4mm acrylic into doors and are manufactured according to the requirements for furniture-fronts based on DIN 68 861.

Mechanical characteristics	Parapan®	Measurement unit	Test regulation
Tensile strength	74	N/mm <sup>2</sup>	DIN 53 455
Tensile elongation at break	5,5	%	DIN 53 455
Module of elasticity	3300	N/mm	DIN 53 457
Apparent density	1,118	g/cm	DIN 53 479
Peel strength of screws	1200	N	Internal test
Tolerance of thickness	± 9 bei 18mm ± 18 bei 4mm	% %	ISO 7823-1

Thermal characteristics	Parapan®	Measurement unit	Test regulation
Coefficient of elongation for 0 to 50°C	70.10 <sup>-6</sup>	1/K	VDE 0304/1
Heat deflection temperature HDT	105	°C	ISO 75

Mechanical characteristics	Parapan®	Measurement unit	Test regulation
Surface roughness	0,003	μ	DIN 4775
Gloss level	High brilliancy	-	Visual evaluated
Abrasion resistance	Good	150 U	DIN 68 861
Scratch resistance	Fulfilled	-	DIN 68 861 T4

Chemical loading	Functional group	Parapan®	MDF Alkyd-resin-varnish	Compressed wood DD-varnish
Coffee, tea	1A	Unchanged	Unchanged	Unchanged
Wine, red and white	1A	Unchanged	Unchanged	Unchanged
Ethanol	1A	Unchanged	Unchanged	Small change
Olive oil	1A	Unchanged	Unchanged	Unchanged
Blackcurrant juice	1A	Unchanged	Unchanged	Unchanged

**Parapan**  
high gloss acrylic

Landau Holdings Ltd, Landau House, Bontoft Avenue, Hull, HU5 4HF

t: 01482 440680 e: info@parapan.co.uk

f: 01482 440683 w: www.landauparapan.co.uk

